

# FY2011 Budget Recommendation

For Period of: July 1, 2010 to June 30, 2011



# Table of Contents

## Department of Human Services Overview

Organization Chart	1
Strategic Plan Goals	2
Community Based Target Population	3
Facility Based Target Population	4
DHS Highest Priorities	5
JCA's Requested Information	6
Funding Overview	7

## Secretariat

Mission Statement	8
Recommended Budget	9

## Developmental Disabilities

Division Mission & Principles	10
Recommended Budget	11
Consumer Expansion - HCBS	12
Funding Sources	13

## SD Developmental Center (SDDC)

Division Mission & Goals	14
Levels of Support	15
Specialized Services	16
Recommended Budget	17
Rightsizing Initiative	18
Funding Sources	19

## Alcohol & Drug Abuse

Division Mission & Goals	20
Drugs of Abuse	21
Recommended Budget	22
Funding Sources	23

## Rehabilitation Services

Division Mission & Goals	24
Individuals Rehabilitated	25
Recommended Budget	26
Funding Sources	27

## Human Services Boards – Informational

28

## Service to the Blind & Visually Impaired

Division Mission & Goals	29
Services Provided	30
Recommended Budget	31
Funding Sources	32

## Human Services Center (HSC)

Division Mission & Goals	33
Admissions	34
Recommended Budget	35
Funding Sources	36

## Mental Health

Division Mission & Goals	37
Recommended Budget	38
Consumer Expansion	39
Funding Sources	40

## Appendix

Acronyms	41
----------	----

# Department of Human Services

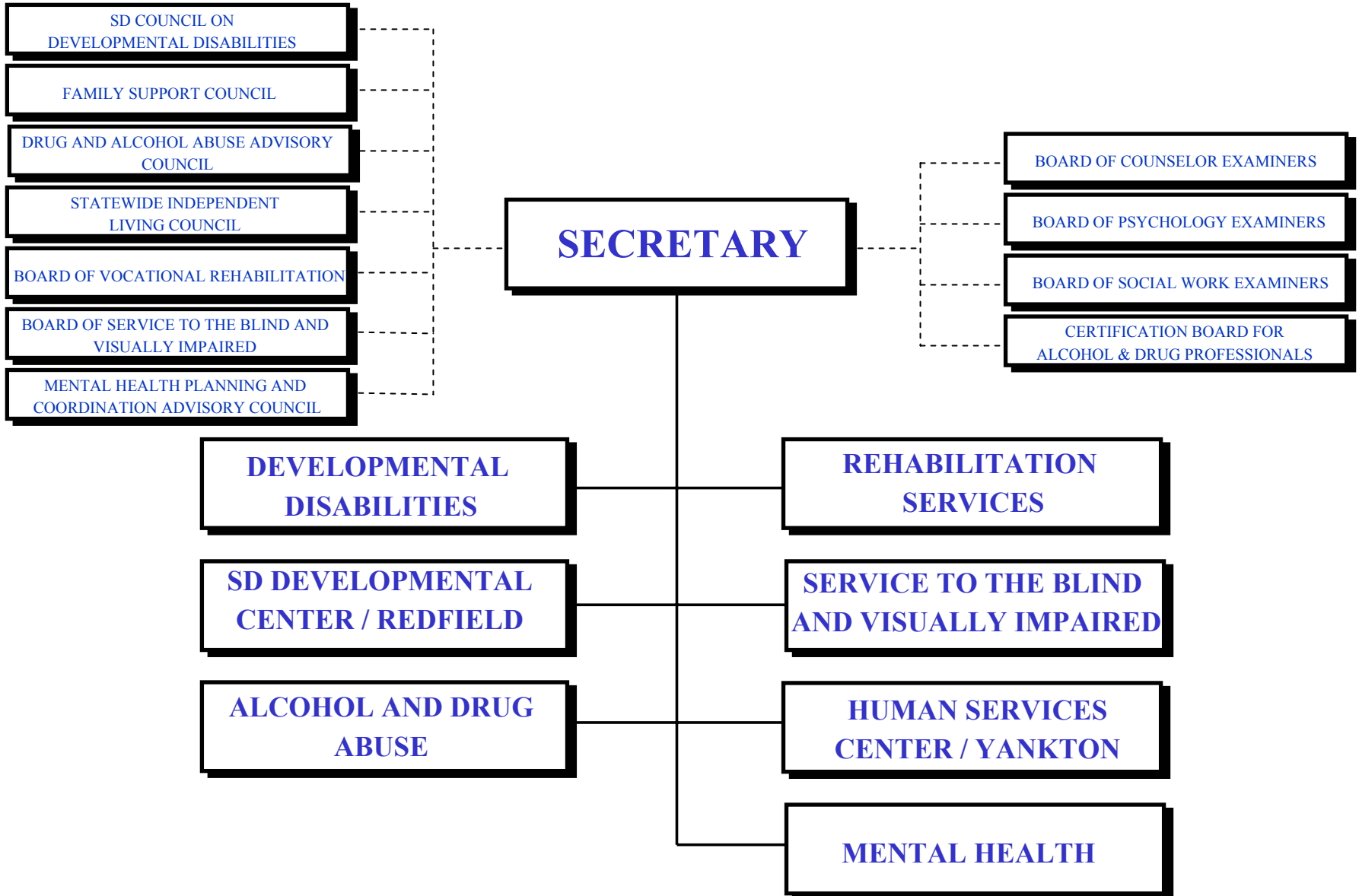

# Department of Human Services

## Strategic Plan Goals

---

**Mission:** *To promote the highest level of independence for all individuals regardless of disability or disorder.*

### **DHS Goals:**

- Person-Centered Services
- Children and Family Services
- Multiple Disabilities or Disorders
- Quality Assurance

# FY11 Community Based Target Population Total Projected Clients – 61,661

---

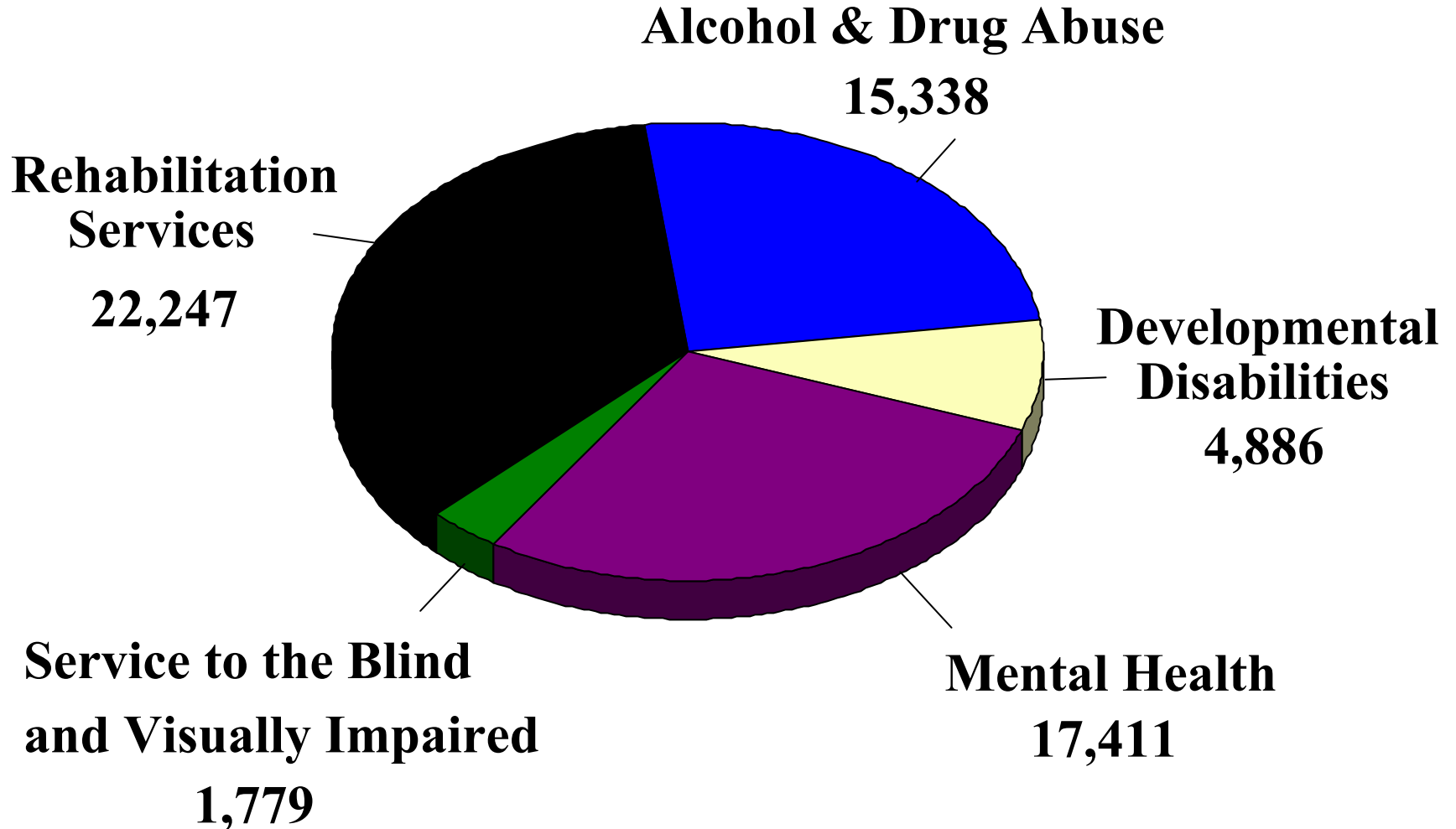

# FY11 Facility Based Target Population

---

## Projected Average Daily Census

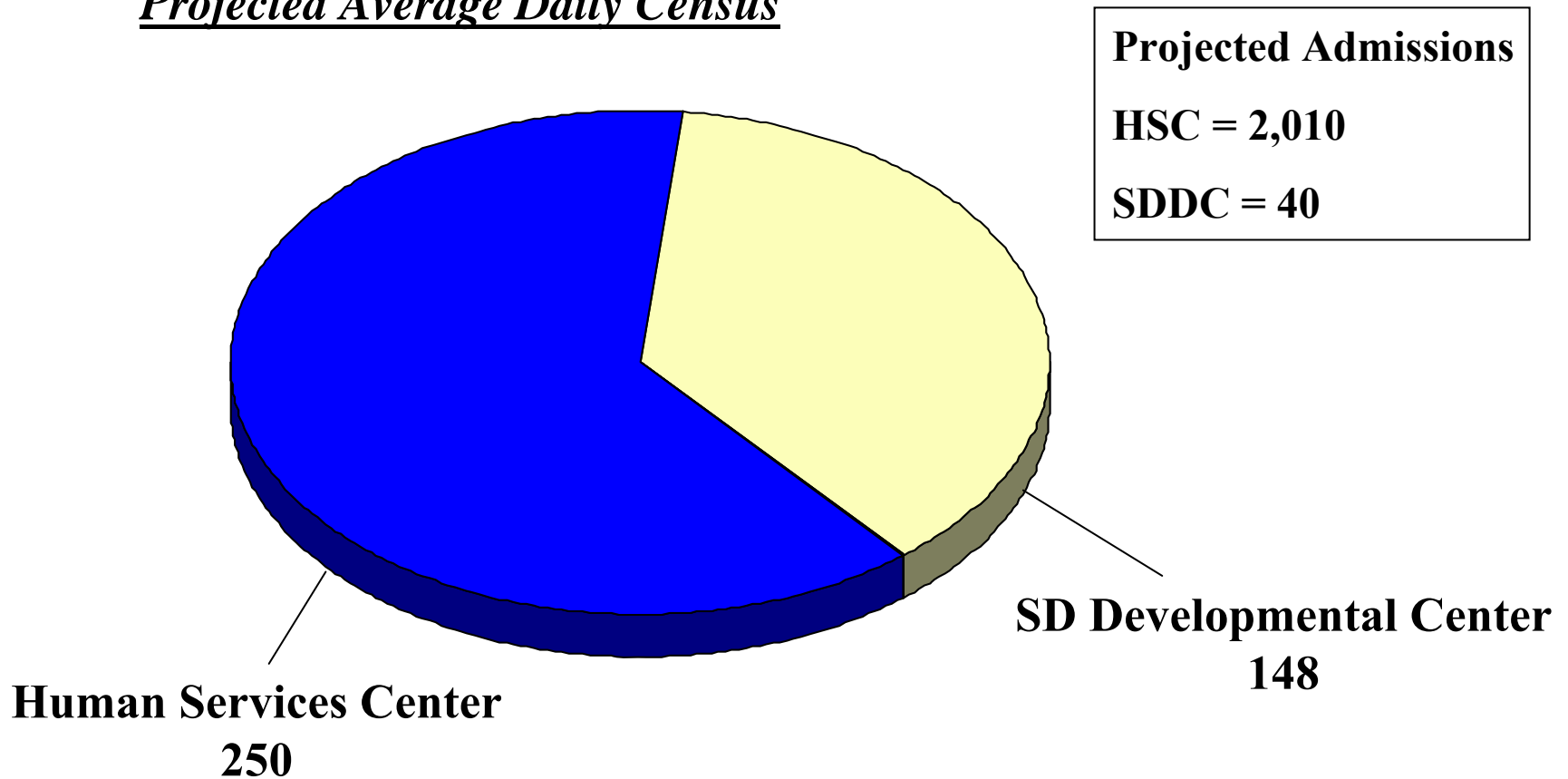

# Department of Human Services

## Highest Priorities Per JCA's Request

---

- Strategic Prevention Framework State Incentive Grant
- Multiple Disabilities or Disorders
- Person-Centered Thinking Initiative
- HSC Dietary Project
- SDDC Rightsizing

# Department of Human Services

## Additional Information Per JCA's Request

---

- Review the success and social impacts of the Department's Alcohol & Drug programs.
- We understand that Minnehaha County is currently not sending committals to the Human Service Center in Yankton. What are the implications for the Center if this continues?
- What are the long-term plans for the SDDC Redfield facility?

# Department of Human Services

**ACTUAL**  
**FY08**

**ACTUAL**  
**FY09**

**BUDGETED RECOMMENDED**  
**FY10**      **FY11**

**Funding: \$226,710,374    \$238,827,773    \$248,648,825    \$256,283,849**

Change from FY10 of: General: \$8,019,025    Federal: (\$391,439)    Other: \$7,438    Total: \$7,635,024  
(-15.0) FTE

# Secretariat

## Mission Statement

*To continuously monitor and review the programs and services of the department; to ensure efficient and effective delivery of services within each division; and, to coordinate the administrative and financial services for the department through policy and budgetary management.*

# Secretariat

**FY11 Total Recommended Budget: \$1,858,699**

**■ Major Items Recommended: \$8,053**

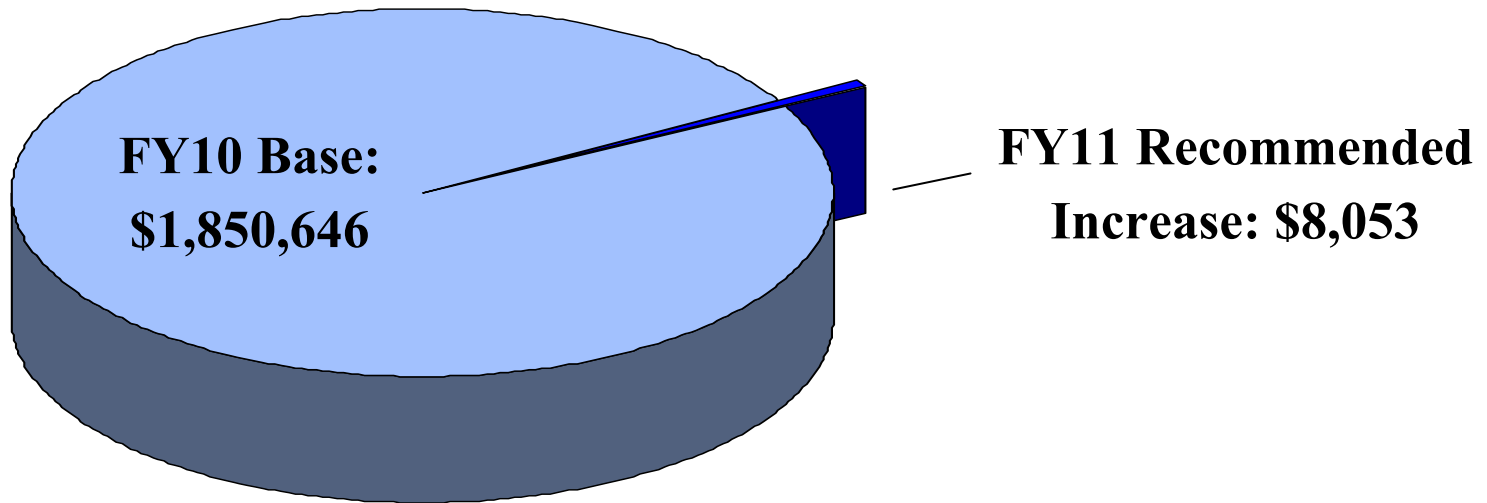

	<b>GENERAL</b>	<b>FEDERAL</b>	<b>OTHER</b>	<b>TOTAL</b>
<b>Minor Items:</b>	<u>\$4,035</u>	<u>\$4,018</u>	<u>\$0</u>	<u>\$8,053</u>
<b>Total:</b>	<b>\$4,035</b>	<b>\$4,018</b>	<b>\$0</b>	<b>\$8,053</b>

# Division of Developmental Disabilities

## Mission Statement

*We ensure that people with developmental disabilities have equal opportunities and receive the services and supports they need to live and work in South Dakota communities.*

## Principles

- We will support people to participate in the life of their community.
- We will honor the importance of relationships with family and friends.
- We will ensure that quality services are available and accessible.
- We will work with providers to enhance services while respecting the dignity of risk and the importance of health and safety.
- We will respect and value cultural diversity.
- We will be good stewards of public funds.

# Developmental Disabilities

**FY11 Total Recommended Budget: \$104,704,094**

**Major Items Recommended: \$2,882,499**

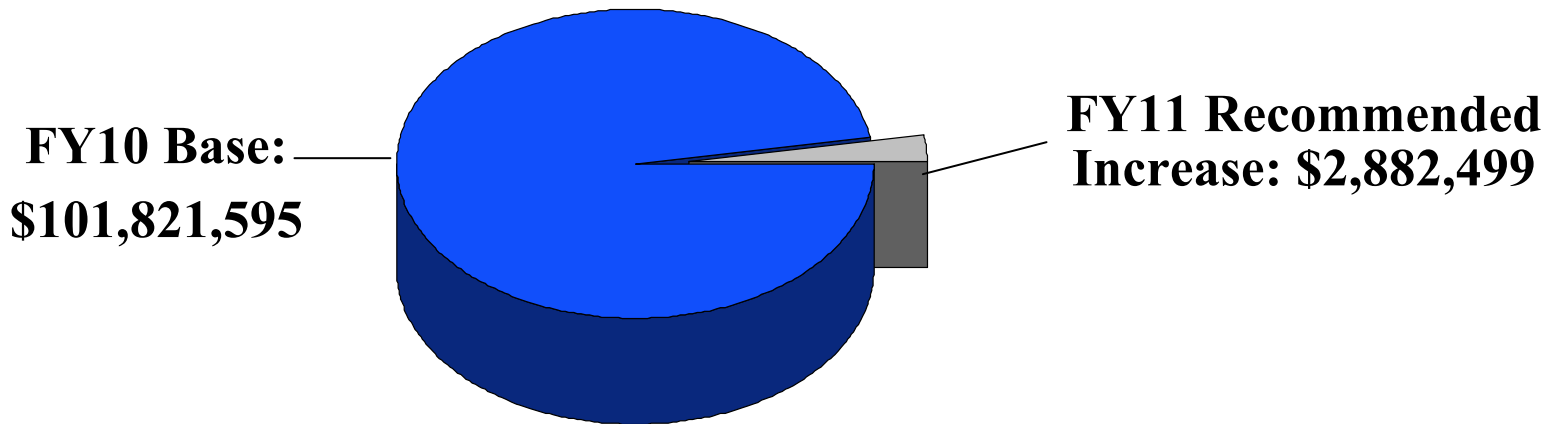

	<b>GENERAL</b>	<b>FEDERAL</b>	<b>TOTAL</b>
<b>FMAP:</b>	\$3,425,447	(\$3,425,447)	\$0
<b>Consumer Expansion:</b>	\$1,003,958	\$1,871,890	\$2,875,848
<b>Minor Items:</b>	\$3,337	\$3,314	\$6,651
<b>Total:</b>	<u>\$4,432,742</u>	<u>(\$1,550,243)</u>	<u>\$2,882,499</u>

# Developmental Disabilities

## FY11 HCBS Consumer Expansion

### Home & Community Based Services

	Individuals	Totals
<b>Discharges:</b>	<b>(86)</b>	<b>(\$3,261,287)</b>
<b>Admissions:</b>	<b>65</b>	<b>\$3,165,848</b>
<b>Kids Turning 21:</b>	<b>*75</b>	<b>\$3,015,083</b>
<b>Absent Bed Days &amp; Cost Share:</b>	<b>NA</b>	<b>(\$43,796)</b>
<b>Total:</b>	<b><u>54</u></b>	<b><u>\$2,875,848</u></b>

\*82 children turning 21 were surveyed as needing services in FY11, 7 will be served by the Family Support 360 Program.

# Developmental Disabilities

## FY11 Funding Sources

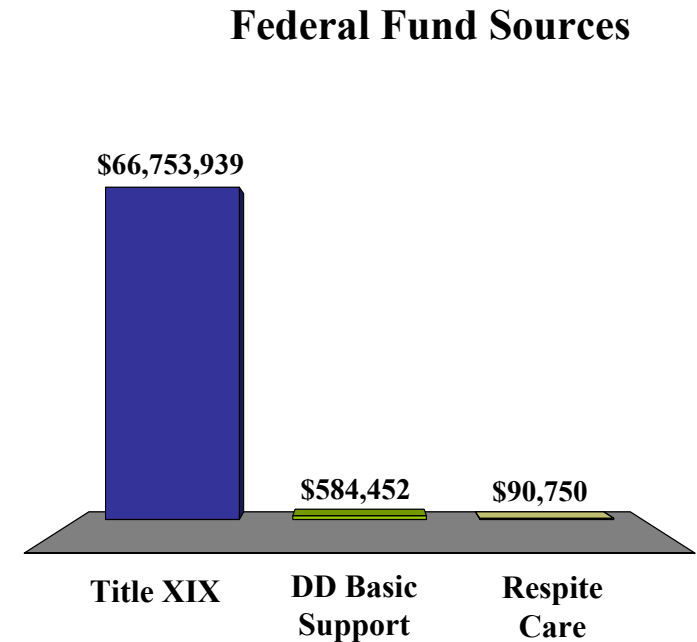
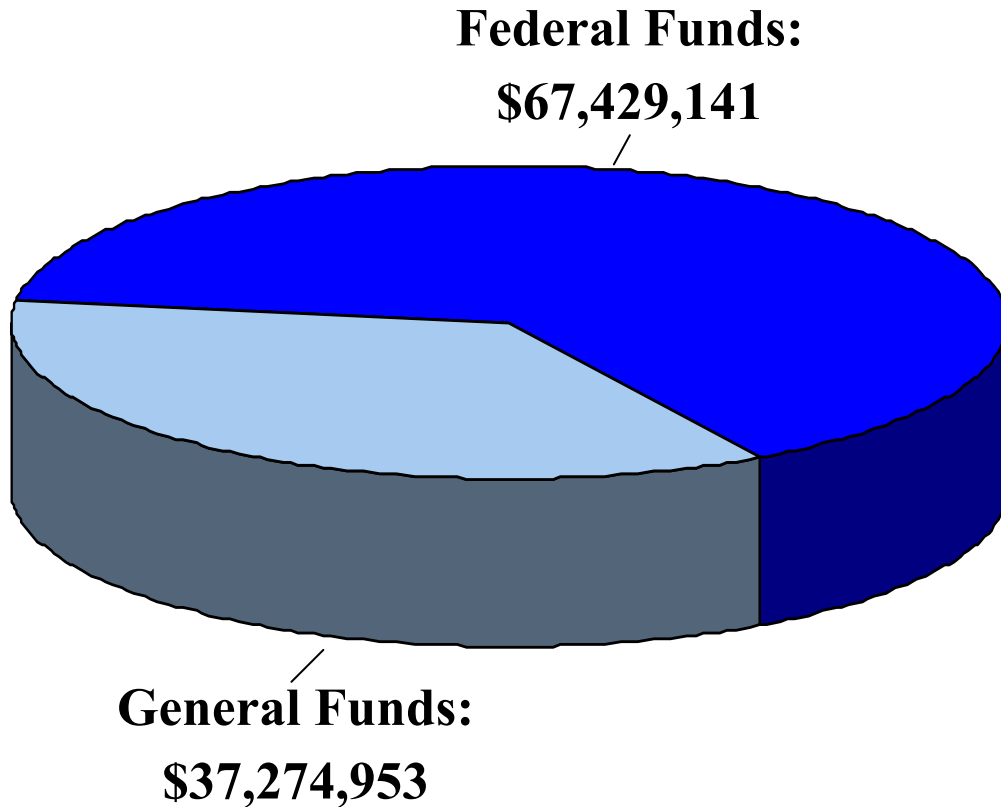

# South Dakota Developmental Center

## Mission Statement

*To provide individualized intensive treatment services to people with developmental disabilities and challenging behaviors only when appropriate services are not available in a less restrictive environment.*

## Priority Goals

- To afford each person the right to privacy, dignity, respect and responsibility by helping them make choices and teaching them that inherent with rights comes responsibility.
- To provide a safe, healthy environment that ensures a person's right to due process and protection from abuse, exploitation, harm, and neglect.
- To provide people with developmental disabilities opportunities to learn and develop skills that allow them to become more independent and enhance their quality of life.
- To encourage active participation of the person's support network (parents, family, friends, significant other, guardian, advocate, conservator, etc.) in determining appropriate services.
- Where appropriate, to provide as a component of the person's education, training and treatment, integrated community services that will transition people successfully into the community.

# South Dakota Developmental Center

## Levels of Support & Supervision

### **Low – 18.8%**

- ▶ More support and supervision than needed in the community
- ▶ 1:3 staff to individual ratio off-campus
- ▶ Eligible for independence or free time on campus
- ▶ Eligible for off-campus employment

### **Moderate – 56.5%**

- ▶ Moderate degree of support and supervision needed
- ▶ 1:2 staff to individual ratio off-campus
- ▶ Eligible to walk independently to specific areas of campus using call ahead procedures

### **Significant – 20.8%**

- ▶ High degree of support and supervision needed
- ▶ 1:1 staff to individual ratio off-campus

### **High – 3.9%**

- ▶ Very high degree of support and supervision needed
- ▶ At least 2:1 staff to individual ratio off-campus
- ▶ Limited access to the community

### **Assessed in the Following Areas:**

- Aggression
- Anger
- Depression
- Eloping Potential
- Inappropriate Sexual Behavior
- Inappropriate Sexual Interest/Arousal
- Impulsive or Compulsive Behaviors
- Level of Responsibility for Current Behavior
- Mental Status
- Motivation
- Relapse Triggers
- Self-Esteem
- Self-Injurious Behaviors
- Substance Abuse
- Suicidal Ideation
- Support Network
- Target Population/Victim Interaction
- Treatment and Training Program Participation
- Work/School Adjustment

# South Dakota Developmental Center

## Specialized Services

### **Intensive Treatment Services**

- Sex Offenders
- Sexual Victims
- Sexual Offender Outreach Services

### **Substance Abuse Treatment**

### **Psychiatric Treatment**

### **Mental Health/Behavior Treatment**

- Group Mental Health Therapy
- Individual Mental Health Therapy
- Family Counseling
- Sensory Diet Therapy
- Corrective Thinking
- Alpha Stim Therapy
- Anger Management Therapy
- Restrictive Behavior Treatment Plans
- Risk Management Plans
- Psychotropic Medications

## Additional Service Needs

### **High Need Chronic Medical Issues Treatment**

- Type I Diabetes
- Implanted Electronic Devices
- Intractable Convulsive Epilepsy
- Traumatic Brain Injury
- Coumadin Therapy
- High Risk for Neutropenia
- Lipid Management

### **Other Specialized Services**

- Audiology
- Speech & Language Pathology
- Dental
- Physical Therapy
- Occupational Therapy
- Pharmacy

### **Evaluation Services**

- Psychological & Psychiatric Evaluations
- Competency Evaluations
- Board Commitment Evaluations
- Psychosexual Evaluations
- Off-Site Behavior Consultations

# South Dakota Developmental Center

**FY11 Total Recommended Budget: \$24,685,261**

**Major Items Recommended: (\$133,373)**

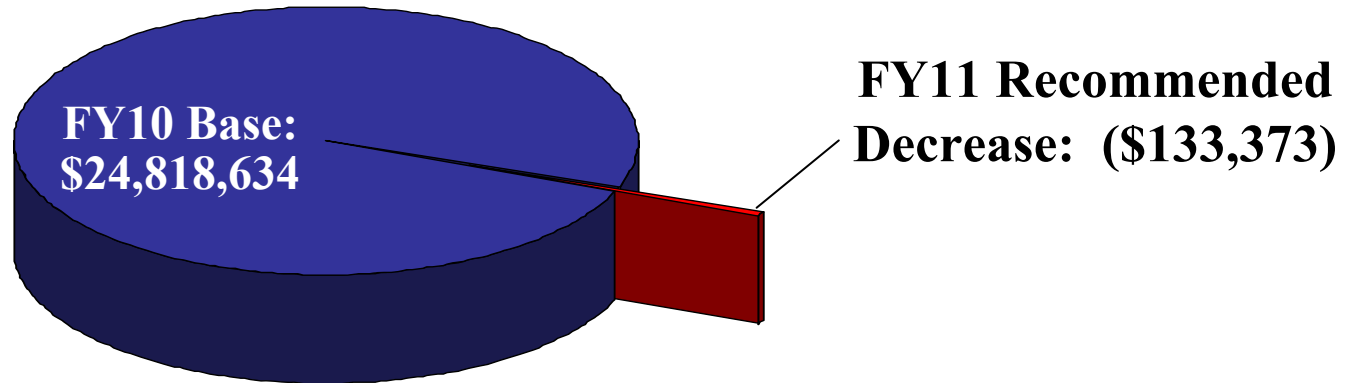

	<b>GENERAL</b>	<b>FEDERAL</b>	<b>OTHER</b>	<b>TOTAL</b>
<b>FMAP:</b>	\$823,263	(\$823,263)	\$0	\$0
<b>Utilities:</b>	(\$52,511)	(\$97,909)	\$0	(\$150,420)
<b>Personal Services: -12.0 FTE</b>	(\$47,500)	(\$88,568)	\$0	(\$136,068)
<b>Minor Items:</b>	<u>\$58,573</u>	<u>\$94,542</u>	<u>\$0</u>	<u>\$153,115</u>
<b>Total:</b>	<u>\$781,825</u>	<u>(\$915,198)</u>	<u>\$0</u>	<u>(\$133,373)</u>

# South Dakota Developmental Center

## Rightsizing Initiative

- FY09
  - Reduction of 3 FTE
- FY10
  - Reduction of 10 FTE
  - Increase of 10 FTE
    - Closure of Redfield Minimum Trusty Unit
  - Campus Employment Opportunity for People Supported
    - Kitchen, Laundry, and Janitorial
  - Reduction of 5.5 FTE
- FY11
  - Reduction of 12 FTE
- Impact of Rightsizing: Reduction of 30.5 FTE and \$1,125,593

# South Dakota Developmental Center

## FY11 Funding Sources

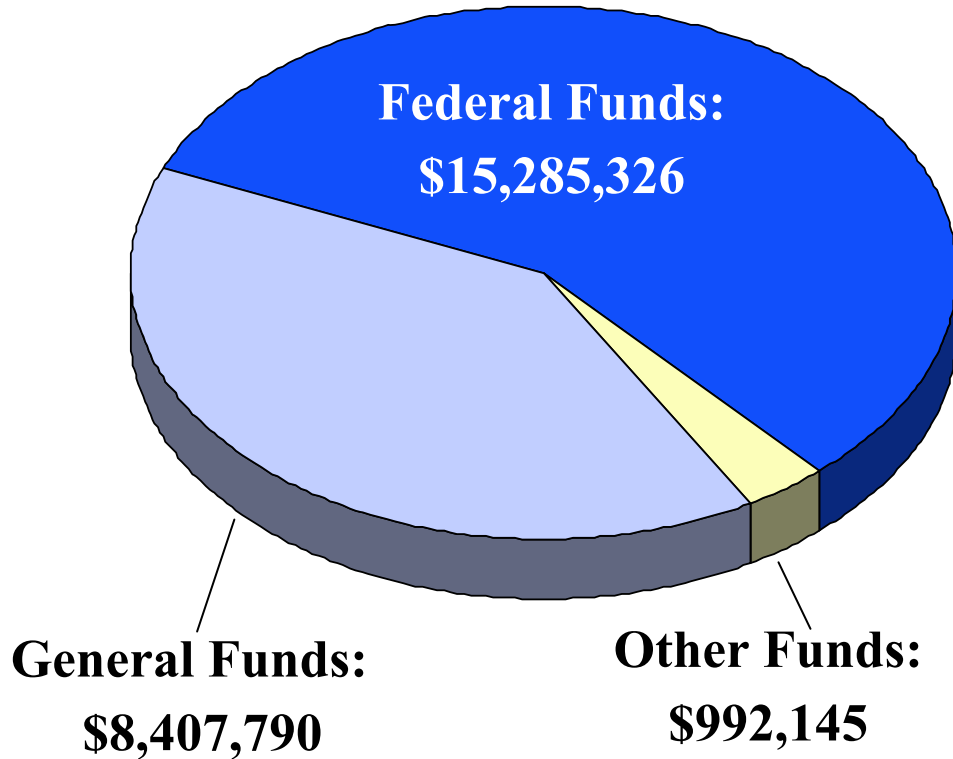

**Federal Fund Sources**

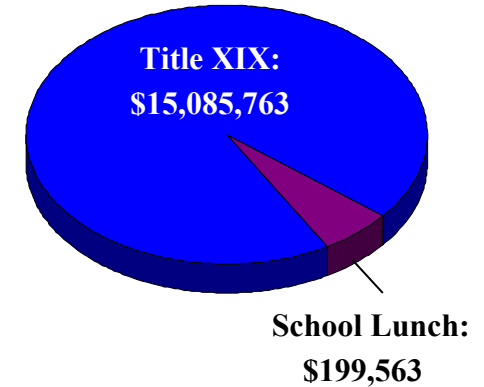

**SDDC Other Funds**

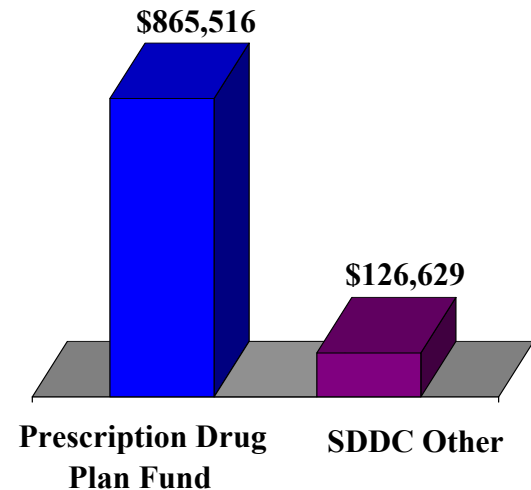

# Division of Alcohol and Drug Abuse

## Mission Statement

*To reduce the prevalence of substance abuse disorders through prevention and treatment services.*

## Priority Goals

- To provide funding for the operations of a comprehensive alcohol and drug prevention and treatment continuum for adolescents and adults at the community level, including relapse programming for youth.
- To operate alcohol and drug programming for the adult and juvenile offenders within the Corrections System.
- To provide specialized treatment services for pregnant women and women with dependent children.
- To provide gambling treatment services.
- To provide case management activities for adolescents and adults entering residential treatment programming.
- To continue to provide specialized methamphetamine programming.

# Alcohol and Drug Abuse

## Primary Drugs of Abuse

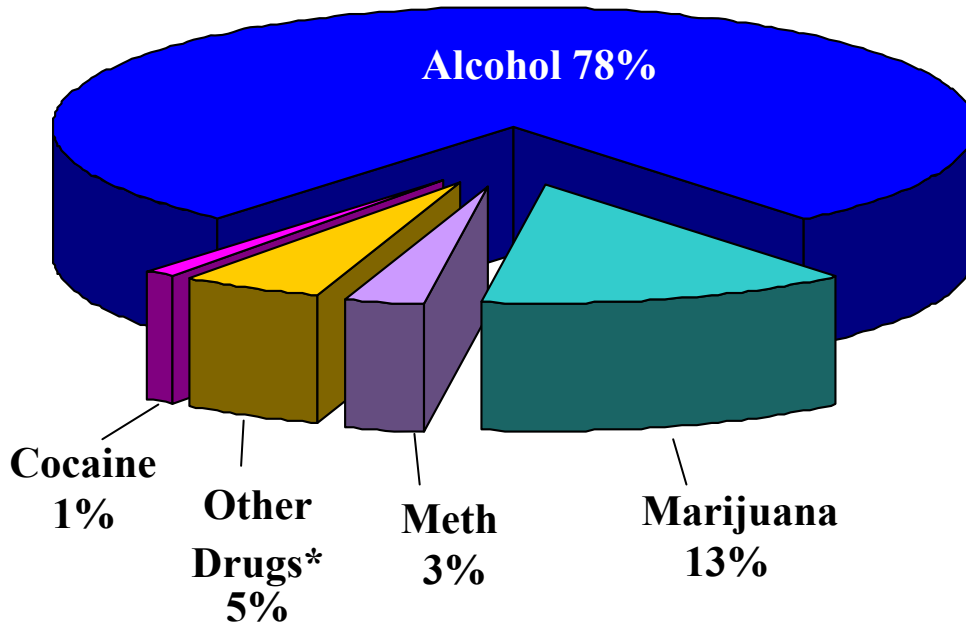

\*Other Drugs: Amphetamine, Opiates, and Synthetics

## Methamphetamines

### Community Treatment

	Methamphetamine Diagnosis	People Served	% of Total
FY03	942	14,812	6%
FY04	1,192	15,235	8%
FY05	1,284	15,377	8%
FY06	1,534	14,177	11%
FY07	2,069	15,069	14%
FY08	1,929	15,146	13%
FY09	1,561	15,112	10%

### Adults Within DOC

	Methamphetamine Diagnosis	% of Adult Male Population	% of Adult Female Population
FY03	235	11%	20%
FY04	338	15%	22%
FY05	403	14%	30%
FY06	827	32%	47%
FY07	681	24%	42%
FY08	683	25%	47%
FY09	659*	23%	42%

\*468 males, 191 females or 659 adults with primary, secondary or tertiary methamphetamine diagnosis

\*\*FY03-FY05 is Primary Only

# Alcohol and Drug Abuse

**FY11 Total Recommended Budget: \$26,259,362**

**Major Items Recommended: \$2,614,067**

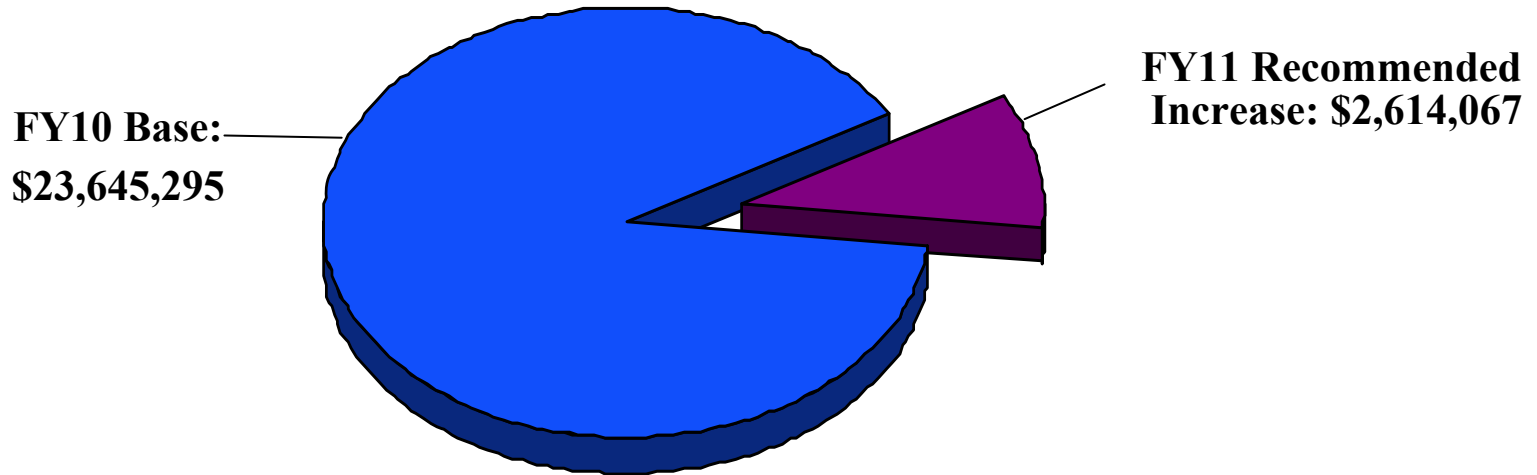

	GENERAL	FEDERAL	OTHER	TOTAL
<b>FMAP:</b>	\$182,861	(\$182,861)	\$0	\$0
<b>SPF SIG:</b>	\$0	\$2,135,724	\$0	\$2,135,724
<b>Title XIX Services:</b>	\$174,645	\$325,627	\$0	\$500,272
<b>Personal Services: -1.0 FTE</b>	(\$14,136)	(\$26,356)	\$0	(\$40,492)
<b>Minor Items:</b>	\$16,515	\$2,048	\$0	\$18,563
<b>Total:</b>	<u>\$359,885</u>	<u>\$2,254,182</u>	<u>\$0</u>	<u>\$2,614,067</u>

# Alcohol and Drug Abuse FY11 Funding Sources

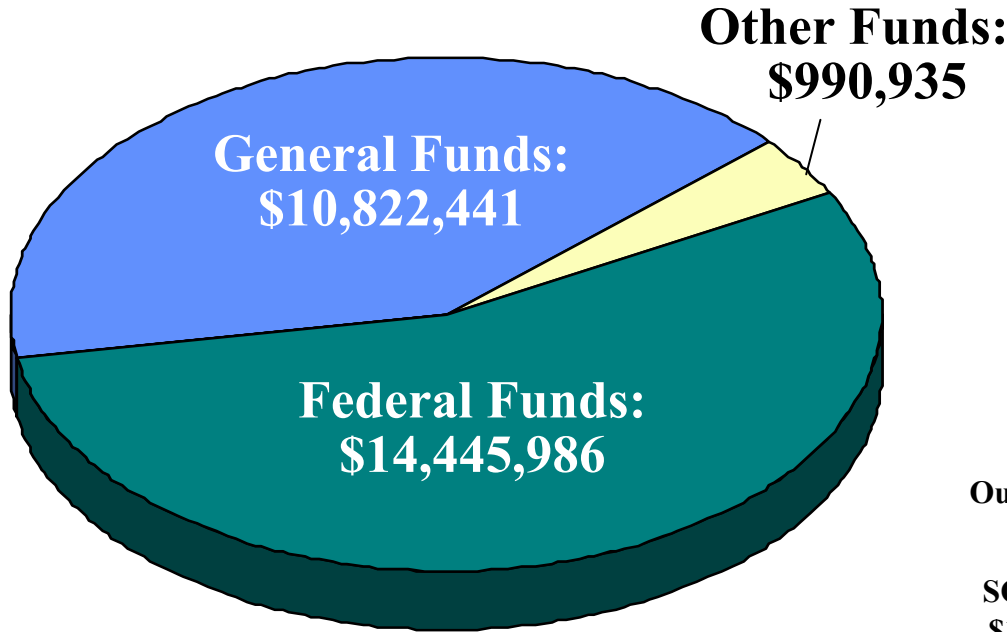

## DADA Other Funds

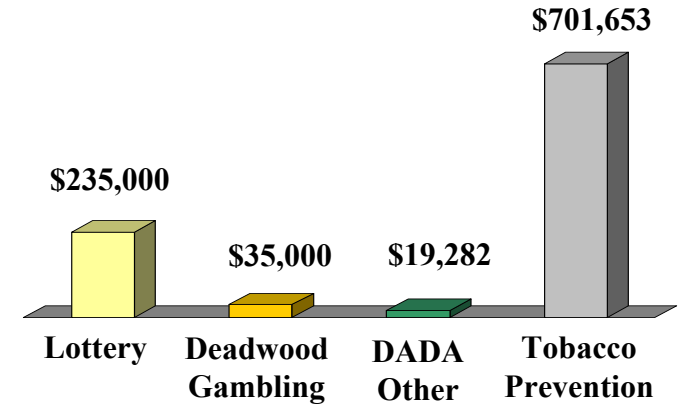

## Federal Fund Sources

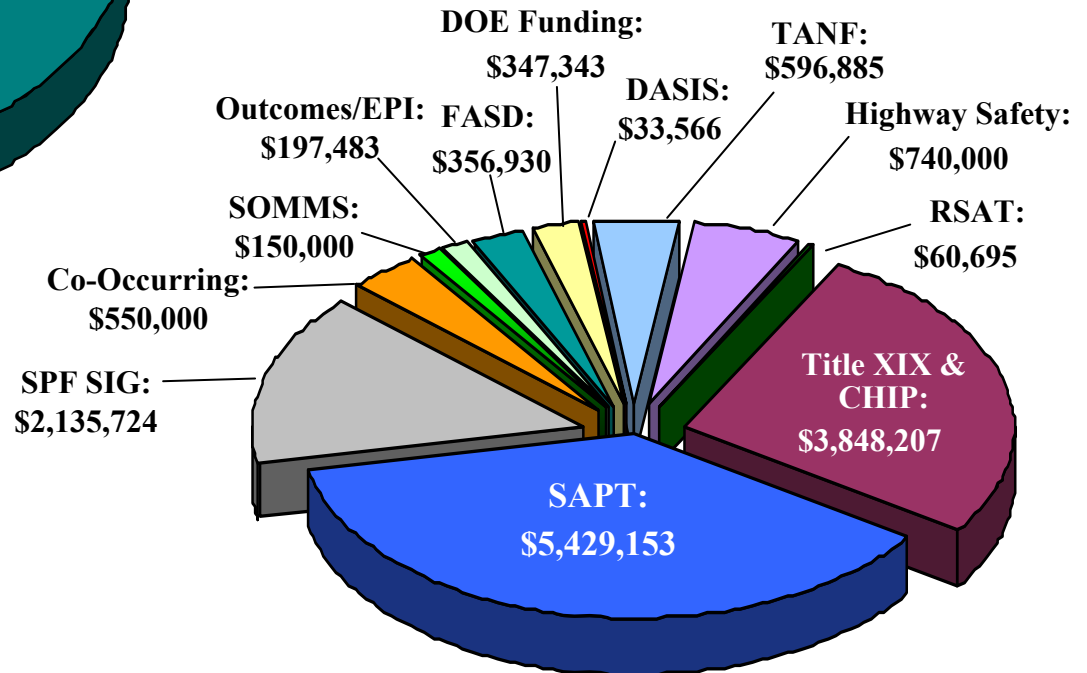

# Division of Rehabilitation Services

## Mission Statement

*To assist individuals with disabilities to obtain employment, economic self-sufficiency, personal independence and full inclusion into society.*

## Priority Goals

- Ensure that services are driven by needs as identified by consumers and employers and result in jobs for people with disabilities.
- Provide education to the citizens of South Dakota on the abilities and rights of individuals with disabilities, thus creating greater opportunities for employment and independent living.
- Provide individuals with disabilities the tools necessary to make informed choices and decisions and to achieve equal opportunity and full inclusion into society.
- Disability Determination Services will determine eligibility for Social Security Disability benefits in an equitable, efficient, cost effective and caring manner.

# Rehabilitation Services

## Primary Impairments

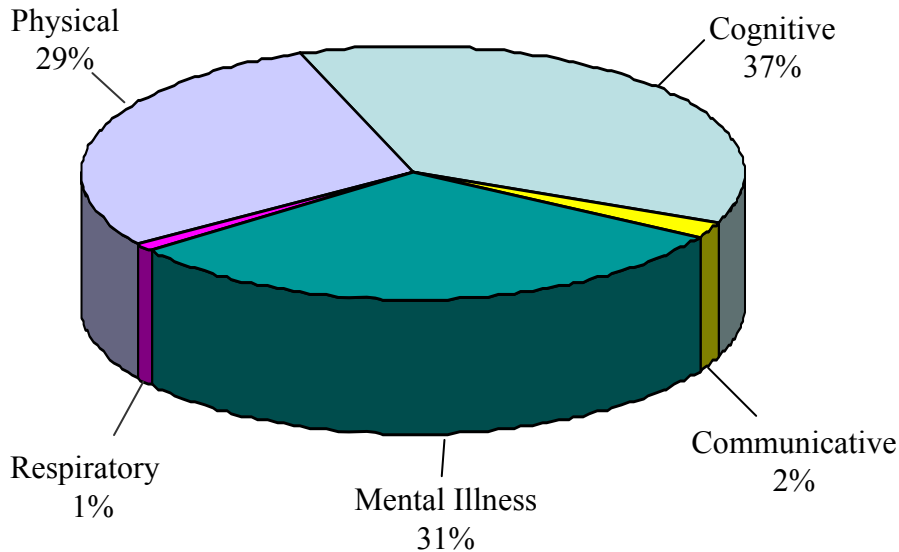

► South Dakota continues to rate in the top tier of states nationally in the percentage of individuals with work disabilities who are employed. U.S. Census Bureau American Community Survey 2007 estimates reveal that South Dakota employment rate is 15% greater than the national average.

► In fiscal year 2009, the average annual income of consumers rehabilitated was \$13,928. Prior to rehabilitation, the average income was \$2,938.

## FY09 Performance Outcomes

Performance Description	At Application	At Closure	Percent of Improvement
Increase in individuals obtaining medical insurance through employment	30	107	357%
Increase in individuals where wages are primary source of support	99	472	477%
Increase of weekly wages	\$56.50	\$267.85	474%
Decreased dependency on public support	232	115	50%

# Rehabilitation Services

**FY11 Total Recommended Budget: \$23,053,154**

**Major Items Recommended: \$578,729**

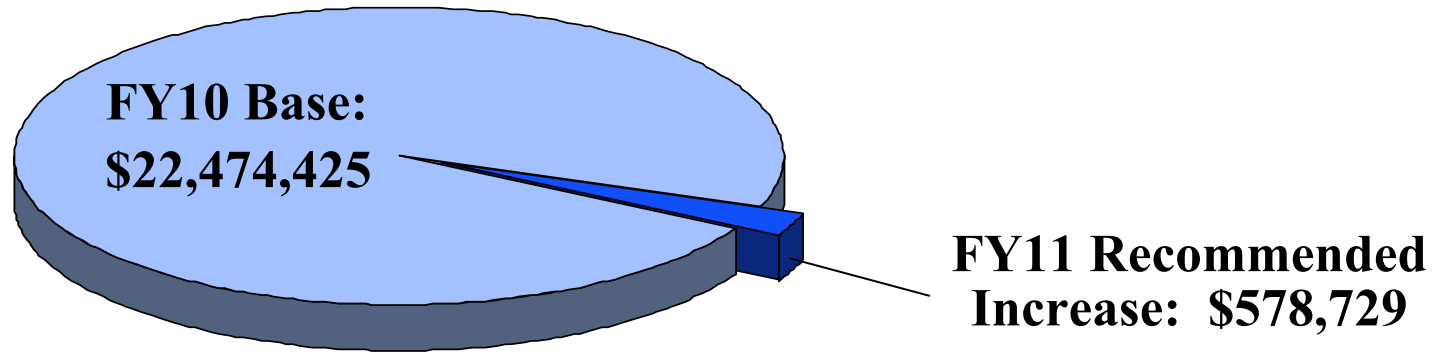

	<b>GENERAL</b>	<b>FEDERAL</b>	<b>OTHER</b>	<b>TOTAL</b>
<b>FMAP:</b>	\$143,502	(\$143,502)	\$0	\$0
<b>ADLS Rate Adjustment:</b>	\$36,777	\$68,570	\$0	\$105,347
<b>DDS Personal Services:</b>	\$0	\$70,362	\$0	\$70,362
<b>Minor Items:</b>	\$83,226	\$319,794	\$0	\$403,020
<b>Total:</b>	<u>\$263,505</u>	<u>\$315,224</u>	<u>\$0</u>	<u>\$578,729</u>

# Rehabilitation Services

## FY11 Funding Sources

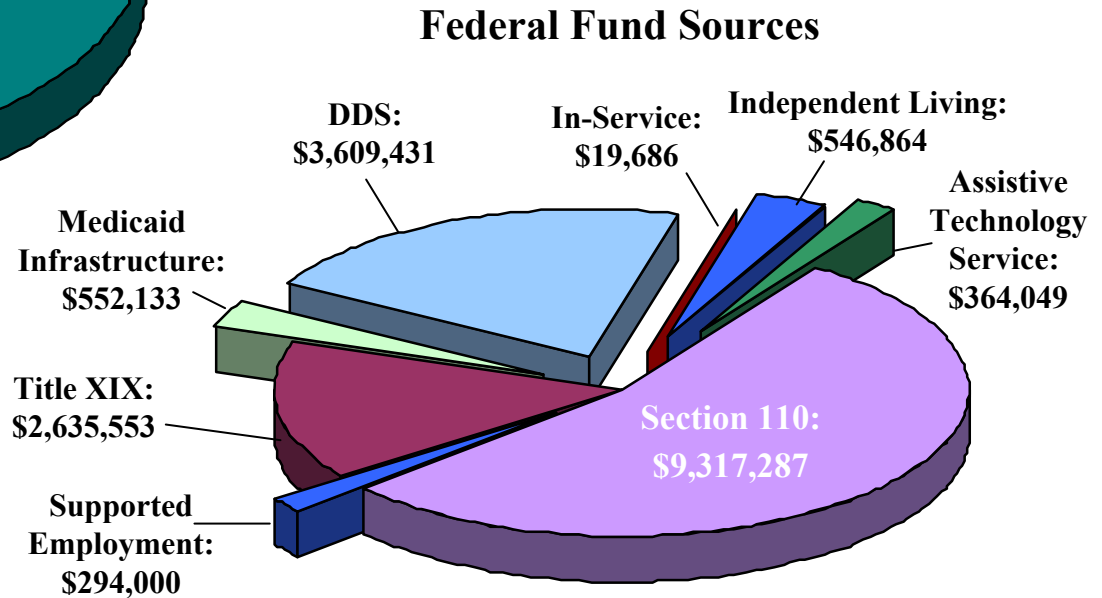
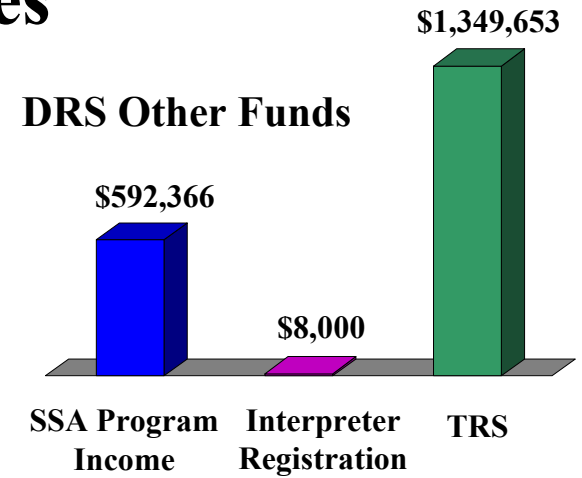
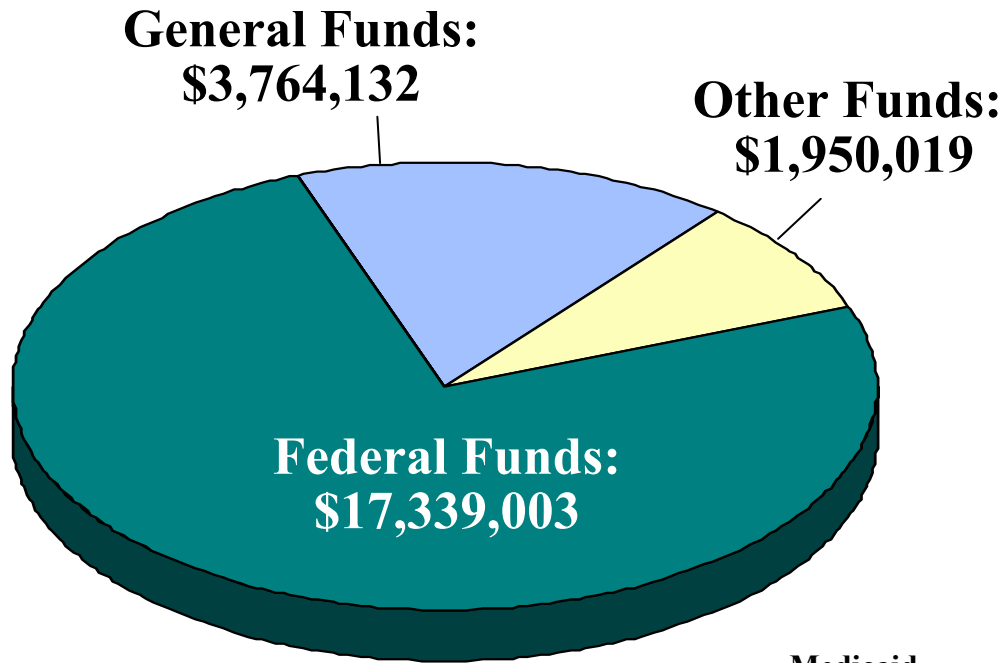

# Human Services Boards - Informational

**FY11 Total Recommended Budget: \$392,044**

■ **Major Items Recommended: \$777**

• <b>Board of Counselor Examiners:</b>	<b>\$6,849</b>
• <b>Board of Psychology Examiners:</b>	<b>\$0</b>
• <b>Board of Social Work Examiners:</b>	<b>\$0</b>
• <b>Certification Board for Alcohol &amp; Drug Professionals:</b>	<b>(\$6,072)</b>
<b>Total:</b>	<b>\$777</b>

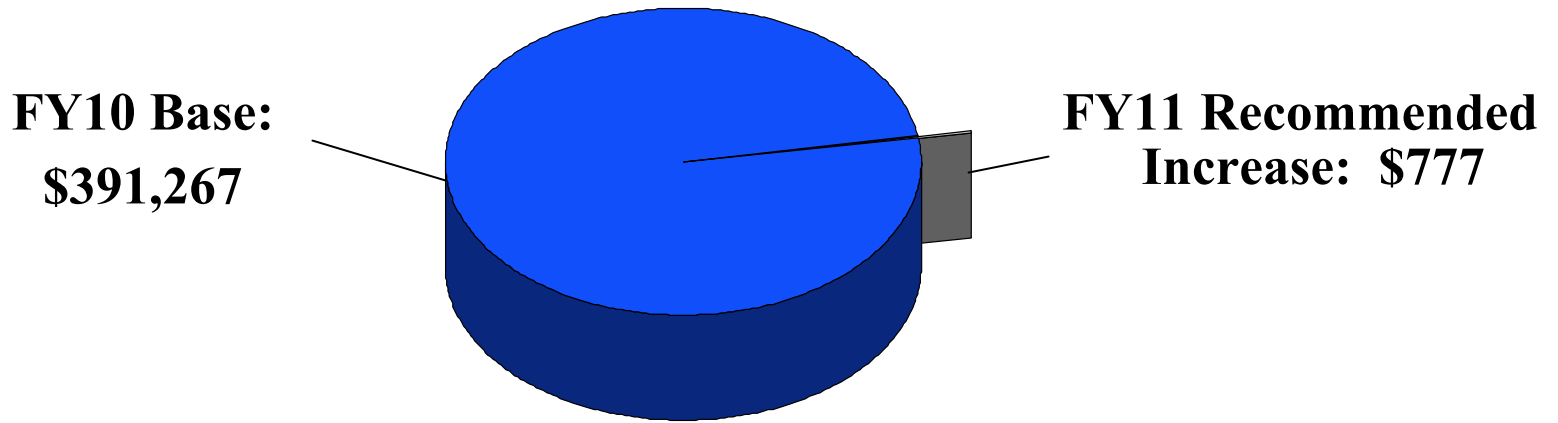

# Service to the Blind & Visually Impaired

## Mission Statement

*To provide individualized rehabilitation services that result in optimal employment and independent living outcomes for citizens who are blind or visually impaired.*

## Priority Goals

- Deliver specialized training in the skills of blindness to include communication (Braille, large print, money identification), orientation and mobility (use of white cane), assistive technology and other skill areas to citizens who are blind or visually impaired on a statewide basis.
- Promote employment of citizens who are blind or visually impaired through training, job development and job placement activities including education of employers on the capabilities of individuals who are blind.
- Training for older blind individuals in alternative techniques and provision of assistive devices to enhance their quality of life and ability to remain living independently in their home communities.

# Service to the Blind & Visually Impaired

Age Range of IL Older Blind Individuals Served in FY09

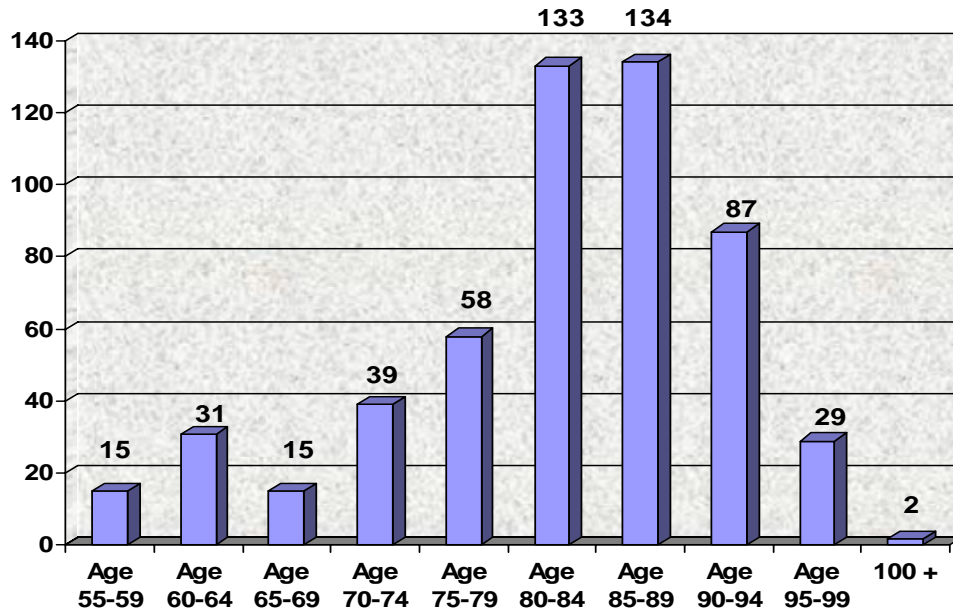

▶ In a recent survey of older blind program participants, 12% of respondents indicated prior to receiving services they had considered entering a nursing home due to vision loss but due to services from SBVI, they felt confident in their ability to remain in their home.

▶ The SBVI Vocational Rehabilitation Program served 571 individuals in Fiscal Year 2009. This represents an increase of 57% compared to 2003.

## Services Provided:

- ▶ Training in alternative techniques to perform tasks with vision loss such as: orientation and mobility, computer training utilizing speech and screen enhancement, communications, home management, and low vision examinations and devices to help maintain independence in individuals homes and at work.
- ▶ Services are provided that assist individuals to obtain or maintain employment to include: guidance and counseling, training, post secondary education, physical restoration, provision of assistive technology services and devices, job placement and job coaching.
- ▶ Training for older blind individuals in alternative techniques and provision of assistive devices to enhance their quality of life and ability to remain living independently in their home communities.

# Service to the Blind & Visually Impaired

**FY11 Total Recommended Budget: \$3,519,391**

**Major Items Recommended: \$103,369**

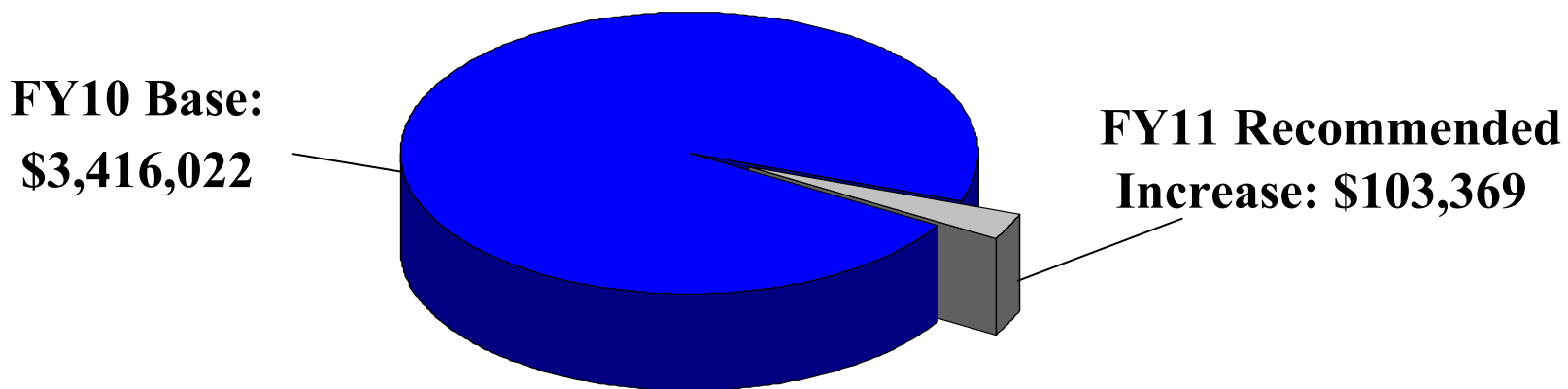

	<b>GENERAL</b>	<b>FEDERAL</b>	<b>OTHER</b>	<b>TOTAL</b>
<b>Minor Items:</b>	<u>\$22,445</u>	<u>\$80,014</u>	<u>\$910</u>	<u>\$103,369</u>
<b>Total:</b>	<u>\$22,445</u>	<u>\$80,014</u>	<u>\$910</u>	<u>\$103,369</u>

# Service to the Blind & Visually Impaired

## FY11 Funding Sources

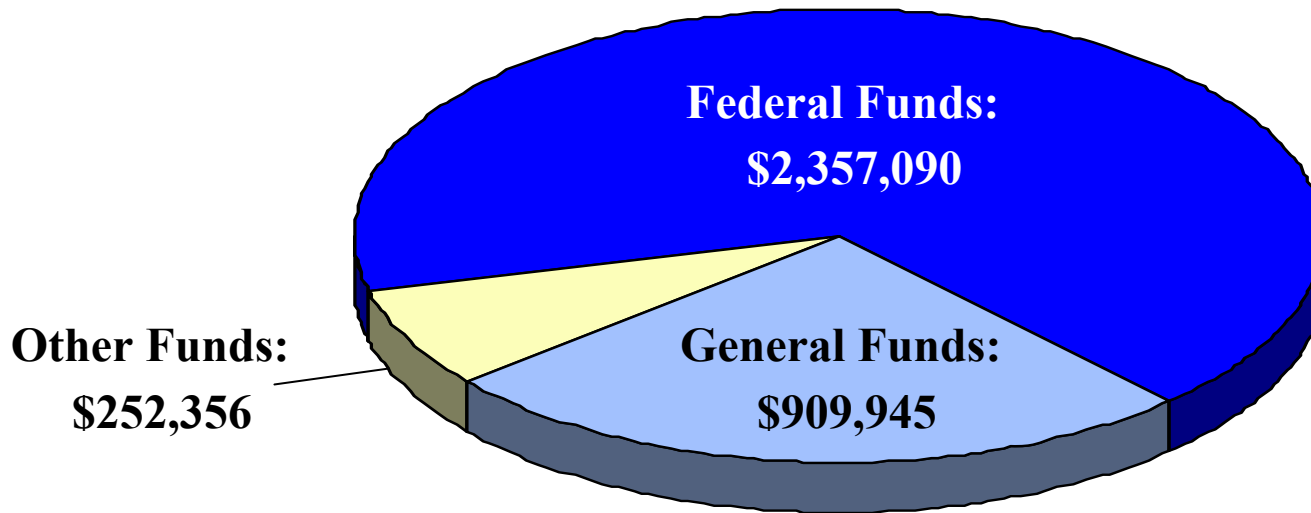

**Federal Fund Sources**

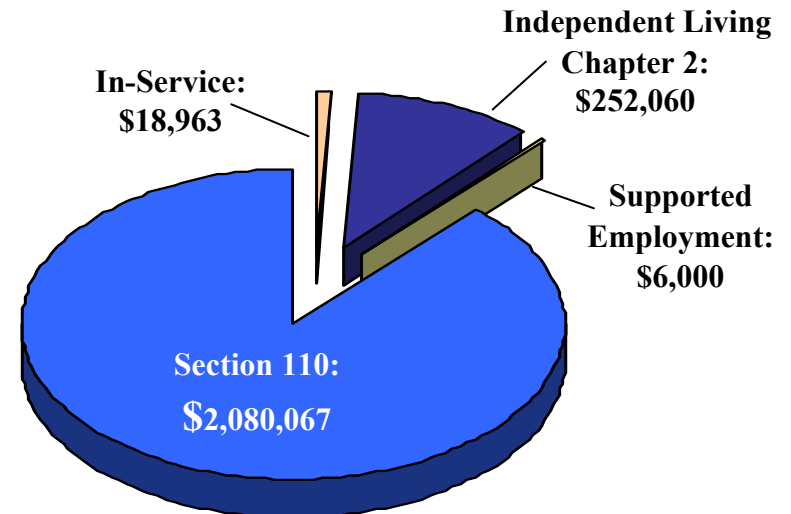

**SBVI Other Funds**

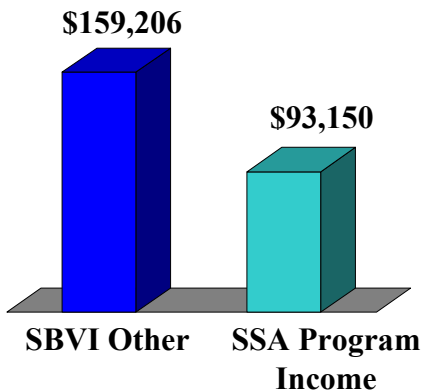

# Human Services Center

## **Mission Statement**

*To provide persons who are mentally ill or chemically dependent with effective, individualized professional treatment that enables them to achieve their highest level of personal independence in the most therapeutic environment.*

## **Priority Goals**

- Provide appropriate, individualized treatment services which meet the unique and changing needs of patients.
- Enable individuals to achieve their highest potential level of functioning.
- Achieve enhanced program integration with other public and private agencies in order to provide successful transition of treatment services for individuals between inpatient and outpatient settings.

# Human Services Center Admissions

## Overall Increase in Admissions

11% increase from  
FY02 to FY09

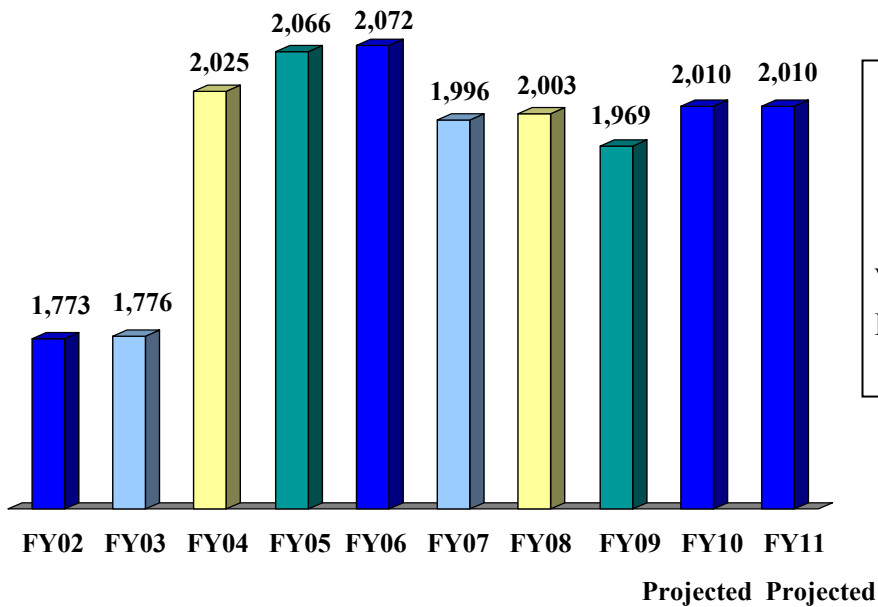

### Admission Type – Adult Acute

	FY02	FY03	FY04	FY05	FY06	FY07	FY08	FY09
<b>Voluntary</b>	33%	29%	27%	26%	24%	25%	23%	22%
<b>Involuntary</b>	67%	71%	73%	74%	76%	75%	77%	78%

# Human Services Center

**FY11 Total Recommended Budget: \$41,880,685**

**Major Items Recommended: \$682,251**

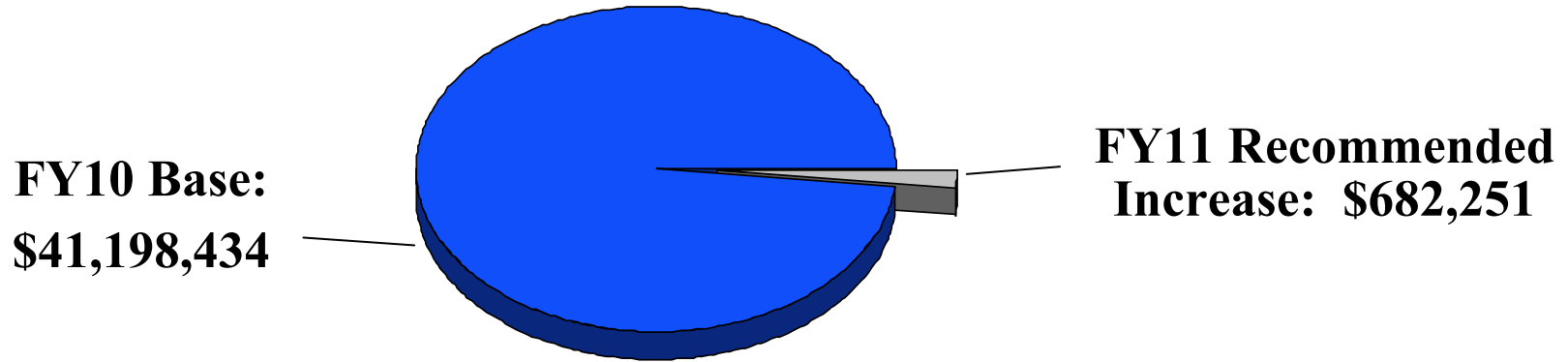

	<b>GENERAL</b>	<b>FEDERAL</b>	<b>OTHER</b>	<b>TOTAL</b>
<b>FMAP:</b>	\$387,999	(\$387,999)	\$0	\$0
<b>Food Service:</b>	\$92,147	\$22,998	\$0	\$115,145
<b>Dietary Bond Payment:</b>	\$394,000	\$0	\$0	\$394,000
<b>Personal Services: -2.0 FTE</b>	(\$12,527)	(\$16,605)	\$0	(\$29,132)
<b>Minor Items:</b>	\$141,200	\$59,952	\$1,086	\$202,238
<b>Total:</b>	<u>\$1,002,819</u>	<u>(\$321,654)</u>	<u>\$1,086</u>	<u>\$682,251</u>

# Human Services Center FY11 Funding Sources

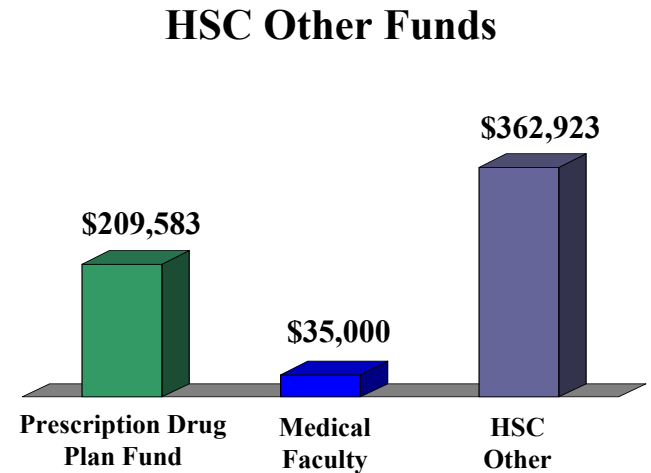
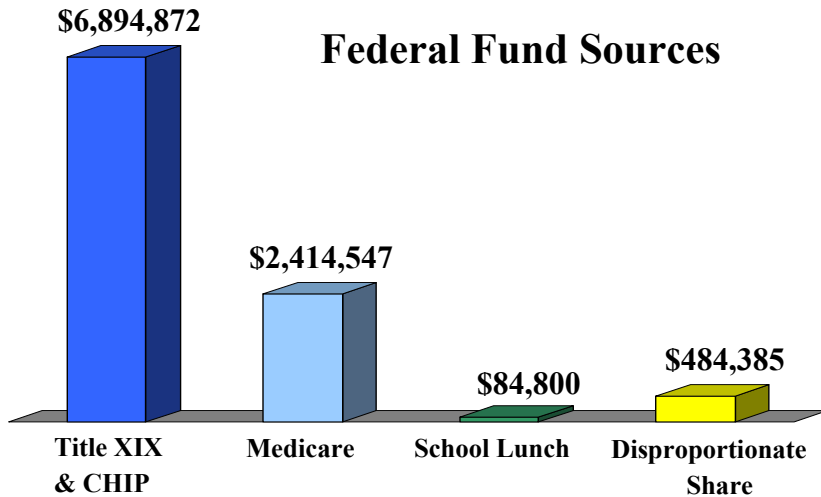
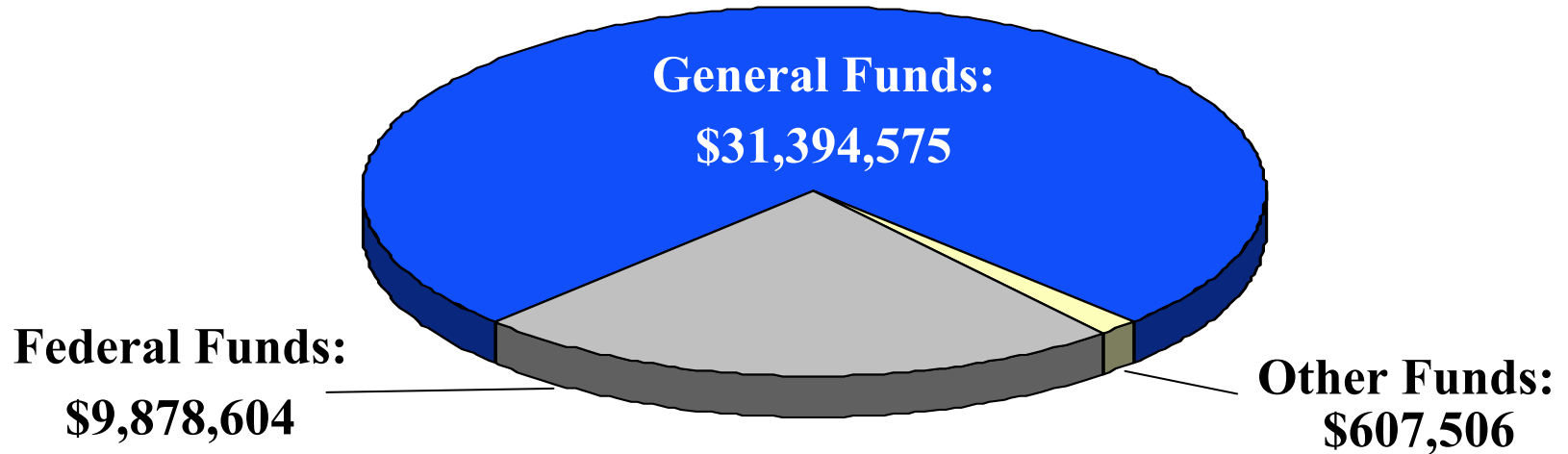

# Division of Mental Health

## Mission Statement

*To ensure children and adults with mental health disorders in our communities have the opportunity to choose and receive effective services needed to promote resilience and recovery.*

## Priority Goals

- Develop an individualized plan of care for every adult with a serious mental illness and child with a serious emotional disturbance.
- Involve consumers and families fully in orienting the mental health system toward recovery.
- Promote the mental health of young children.
- Screen for co-occurring mental and substance use disorders and link with integrated treatment strategies.
- Improve access to quality care that is culturally competent.

# Mental Health

**FY11 Total Recommended Budget: \$29,931,159**

**Major Items Recommended: \$898,652**

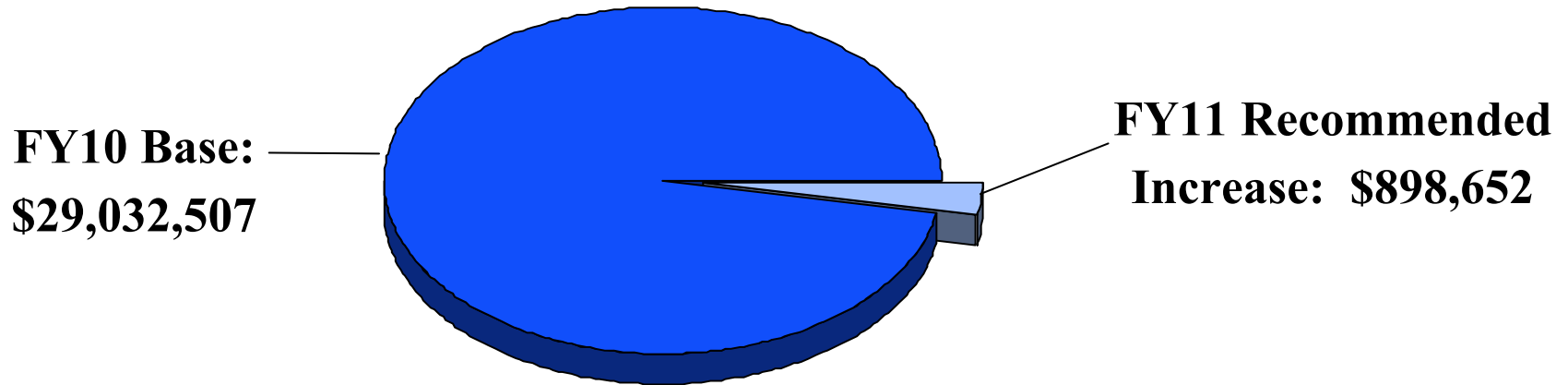

	<b>GENERAL</b>	<b>FEDERAL</b>	<b>OTHER</b>	<b>TOTAL</b>
<b>FMAP:</b>	\$559,837	(\$559,837)	\$0	\$0
<b>Children's SED Waiting List:</b>	\$137,437	\$90,039	\$0	\$227,476
<b>Adult CARE Waiting List:</b>	\$166,286	\$68,579	\$0	\$234,865
<b>Outpatient Services:</b>	\$285,224	\$142,572	\$0	\$427,796
<b>Minor Items:</b>	\$2,985	\$865	\$4,665	\$8,515
<b>Total:</b>	<u>\$1,151,769</u>	<u>(\$257,782)</u>	<u>\$4,665</u>	<u>\$898,652</u>

# Mental Health Consumer Expansion

## Services for Children with SED and Families

The estimated prevalence of children with SED in eligible households was 12,155 in 2000 and the division funded services for 5,072 children served by Community Mental Health Centers in FY09.

## Services for Adults with SPMI

The estimated prevalence of adults with SPMI in eligible households was 11,191 in 2000 and the division funded services for 5,118 adults served by Community Mental Health Centers in FY09.

## FY11 Recommended Budget

	Numbers	Totals
<b>Children's SED Waiting List:</b>	<b>148</b>	<b>\$227,476</b>
<b>Adult CARE Waiting List:</b>	<b>107</b>	<b>\$234,865</b>
<b>Total:</b>	<b>255</b>	<b>\$462,341</b>

# Mental Health FY11 Funding Sources

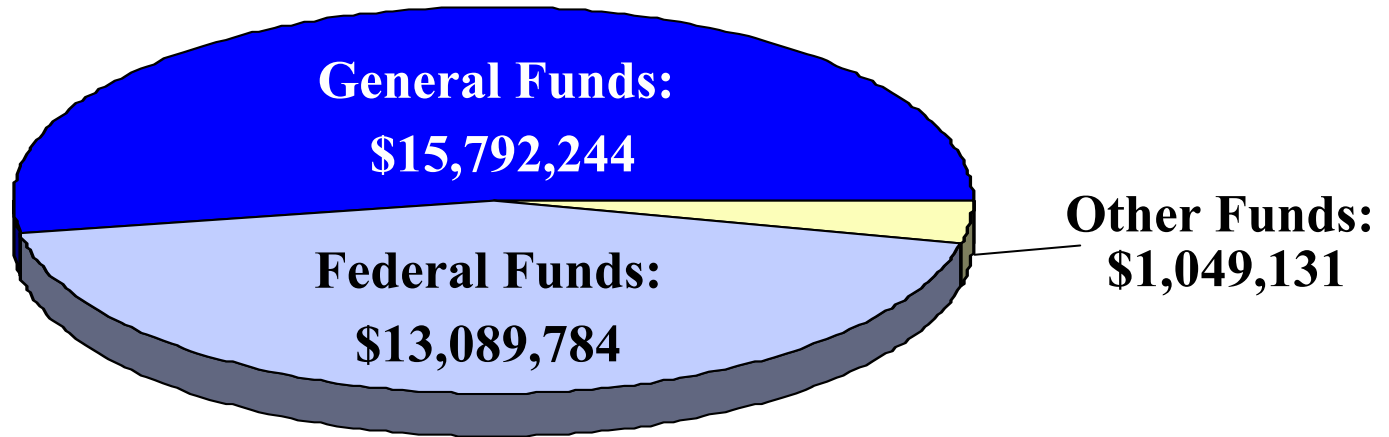

## Federal Fund Sources

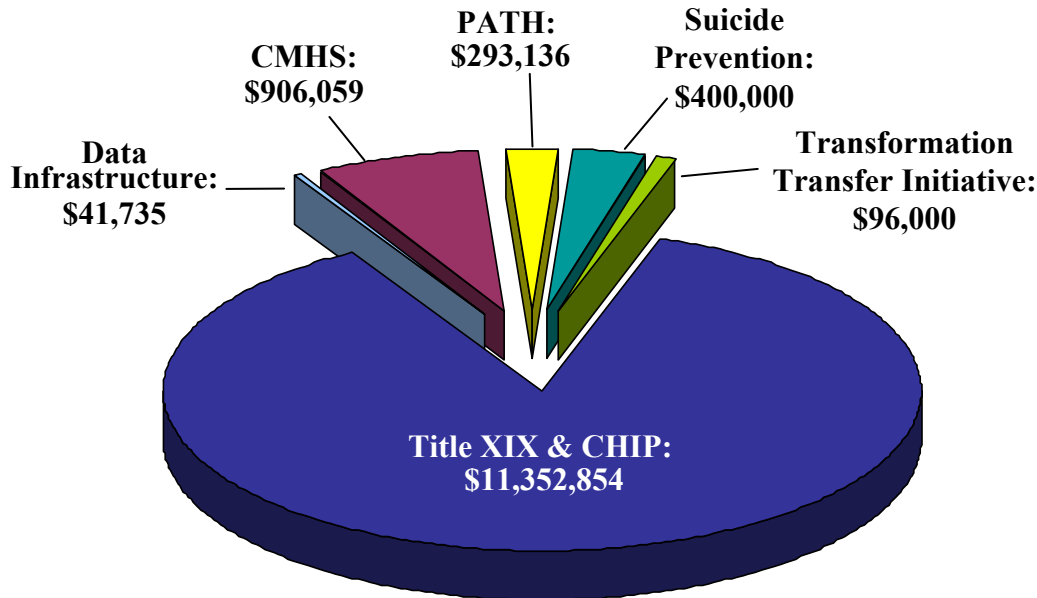

## DMH Other Funds

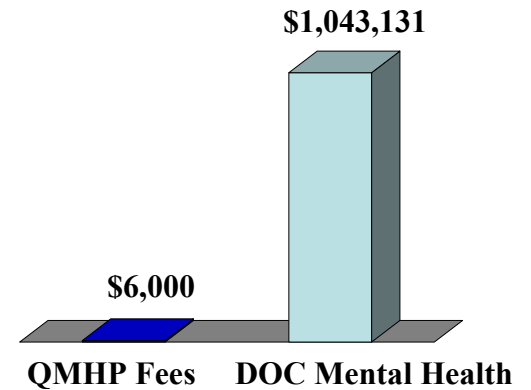

# Department of Human Services

## Budget Presentation Acronyms

*ADLS – Assistive Daily Living Services*

*CARE – Continuous Assistance, Rehabilitation, and Education*

*CHIP – Children’s Health Insurance Program*

*CMHS – Community Mental Health Services Block Grant*

*DASIS – Drug & Alcohol Service Information System*

*DDS – Disability Determination Services*

*DOE – Department of Education*

*DOC – Department of Corrections*

*FASD – Fetal Alcohol Spectrum Disorders*

*FMAP – Federal Medical Assistance Percentage*

*HCBS – Home & Community Based Services*

*ICF/MR – Intermediate Care Facility for the Mentally Retarded*

*IMPACT – Individualized Mobile Program for Assertive Community Treatment*

*IMT – Intensive Methamphetamine Treatment*

*Outcomes/EPI – State Outcomes Measurement/State Epidemiological Outcomes*

*PATH – Projects for the Assistance in Transition from Homelessness*

*QMHP – Qualified Mental Health Professional*

*RSAT – Residential Substance Abuse Treatment*

*SAPT – Substance Abuse Prevention & Treatment Block Grant*

*Section 110 – Basic Support Program – Rehabilitation Services / Service to the Blind & Visually Impaired*

*SED – Serious Emotional Disturbance*

*SPF SIG – Strategic Prevention Framework (SPF) State Incentive Grant (SIG)*

*SPMI – Severe and Persistent Mental Illness*

*SSA – Social Security Administration*

*TANF – Temporary Assistance to Needy Families*

*TBI – Traumatic Brain Injury*

*Title XIX – Medicaid*

*TRS – Telecommunication Relay Services*